

EO GENIUS 2

↘ INSTALLATION & COMMISSIONING GUIDE



→ TABLE OF CONTENTS

Important: Read carefully before use. Keep for future reference.

- 1.0 Introduction
 - 1.1 High level sequence
 - 1.2 Pre-installation information
- 2.0 Installation instructions for the EO Genius 2
 - 2.1 Charger installation instructions
 - 2.2 Important charger information
- 3.0 Wiring connections
 - 3.1 Physical connections
- 4.0 Software configuration of the EO Genius 2
 - 4.1 Initial steps
 - 4.2 Log in to the Genius 2 user interface.
 - 4.3 Configure the device parameters.
 - 4.3.1 Info page
 - 4.3.2 CSMS page
 - 4.3.3 Smart charging page
 - 4.3.4 Network LAN/Wi-Fi Page
 - 4.3.5 Network GSM - EO SIM Page
 - 4.3.6 Installer page
 - 4.3.7 Load page
- 5.0 EO Genius 2 power up
 - 5.1 Charger status light on power-up
 - 5.2 Normal operation
- 6.0 Additional information
 - 6.1 Firmware updates
 - 6.1.1 Receiving the firmware images
 - 6.1.2 Apply the images
 - 6.2 Security
 - 6.3 Trouble shooting
 - 6.4 PEN fault detection
 - 6.5 Final notes
- 7.0 Further technical support

→ 1.0 INTRODUCTION

This document is intended for both Small and medium-sized enterprises (SME) and Charge point operators (CPO) installation purposes and details how to install and configure the EO Genius 2. It covers the physical installation and the software configuration required to enable the charger to communicate to the appropriate OCPP back office.

It includes:

- + How to mount and wire up the EO Genius 2.
- + How to access the charger's user interface.
- + How to configure your Genius 2 for your respective software:
 - + SME
 - + CPO
- + Charger's LED status light.



It is important to note that the information in this document is subject to change without notice as the EO Genius 2 product evolves, please download the latest version from www.eocharging.com/support.

HOW DO I KNOW WHICH SOFTWARE CONFIGURATION SET UP TO FOLLOW?



SMEs include fleet operators and the majority of commercial installs. SMEs represent 99% of all businesses in the EU and is the default way to configure your EO Genius 2 for the majority of EO's customers.



CPOs build EV charging stations, install hardware from a variety of electric vehicle supply equipment (EVSE) vendors, and ensure optimal ongoing EV charging operations. They usually have their own back-office portal which will require different configuration settings which can be found by following section 4.3.2.

1.1 HIGH LEVEL SEQUENCE

The high-level installation sequence is:

- + Physically install the product.
- + Power up the unit.
- + When the LED turns from white to blue, then the Wi-Fi hotspot is available.
- + Join the Wi-Fi hotspot (which is available for 10min) at <https://10.10.10.1>.
- + Configure the unit and log out.
- + When the hotspot turns off then the charger will connect to the configured Cloud based Charging Station Management System.

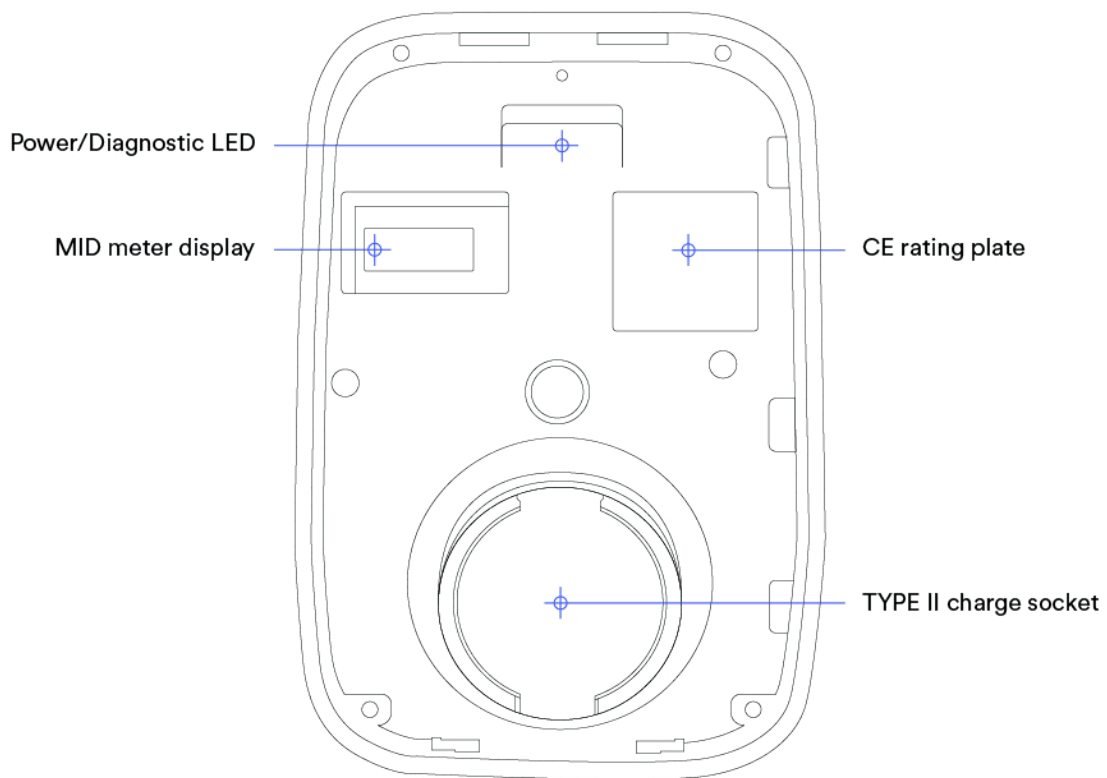

Figure 1: EO Genius 2 labelled backplate.

1.2 PRE-INSTALLATION INFORMATION

Network (LAN) connectivity:

When using a hard-wired connection to a LAN, make sure a working connection to the client's network is available prior to installation or your chargers will fail the online tests.

Wi-Fi connectivity:

If the Genius 2 is to use Wi-Fi for its internet connection to a back-office platform, before fitting the device in place, it is recommended that the strength and integrity of the Wi-Fi signal is checked. If a weak Wi-Fi signal is present, then there is a chance that the installation of the EO Genius 2 may fail. To check that the Wi-Fi signal is strong enough please complete the following steps:

1. Utilise a suitable Wi-Fi analyser mobile device app to verify signal stability, strength, and interference levels.
2. Using a mobile device, connect to the premises' Wi-Fi router.
3. Measure the data rate and signal noise. The data rate should be greater than 5mbps and using an appropriate mobile app, measure the signal noise [RSSI] value which should be circa -60dBm.

If the Wi-Fi is not suitable, a couple of options exist:

1. Install a 2.4GHz Wi-Fi booster.
2. Use the hard-wired ethernet option.
3. Request a charger with the 4G GSM internal modem.

↳ HARDWARE INSTALLATION

→ 2.0 INSTALLATION INSTRUCTIONS FOR EO GENIUS 2

2.1 CHARGER INSTALLATION INSTRUCTIONS

1. What is in the box.

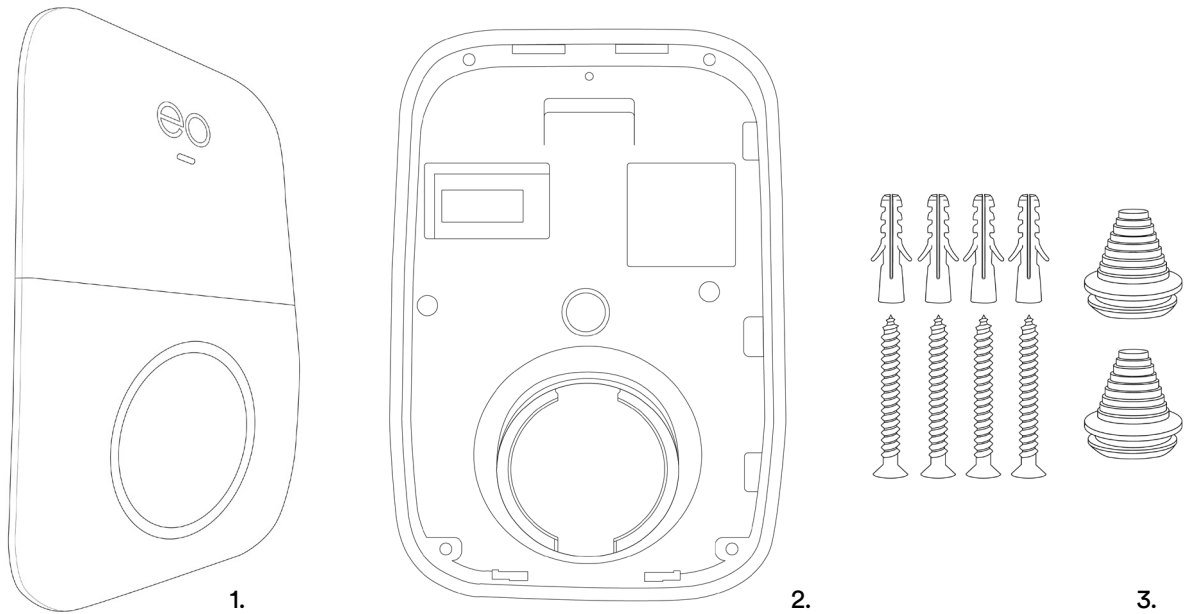

Figure 2: Box contents.

1. EO Genius 2 fascia
2. Genius 2 housing
3. Stepped grommets and charger mounting screws

2. Remove the EO Genius 2 from the packaging. The fascia should be put to one side and left in its wrapping. Using a long reach 4mm hex key, loosen the centre two housing securing screws followed by the four outer screws.

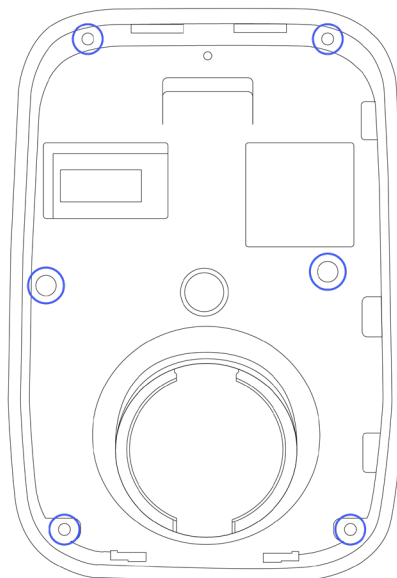

Figure 3: EO Genius 2 backplate.

3. On the bottom of the base, pop out the caps from the cable entry holes. Fit the appropriate glands or stepped grommets for the incoming cables. There are four cable entry holes available:
 - a. Power – rear entry [green]
 - b. Power – bottom entry [red]
 - c. Ethernet [blue]

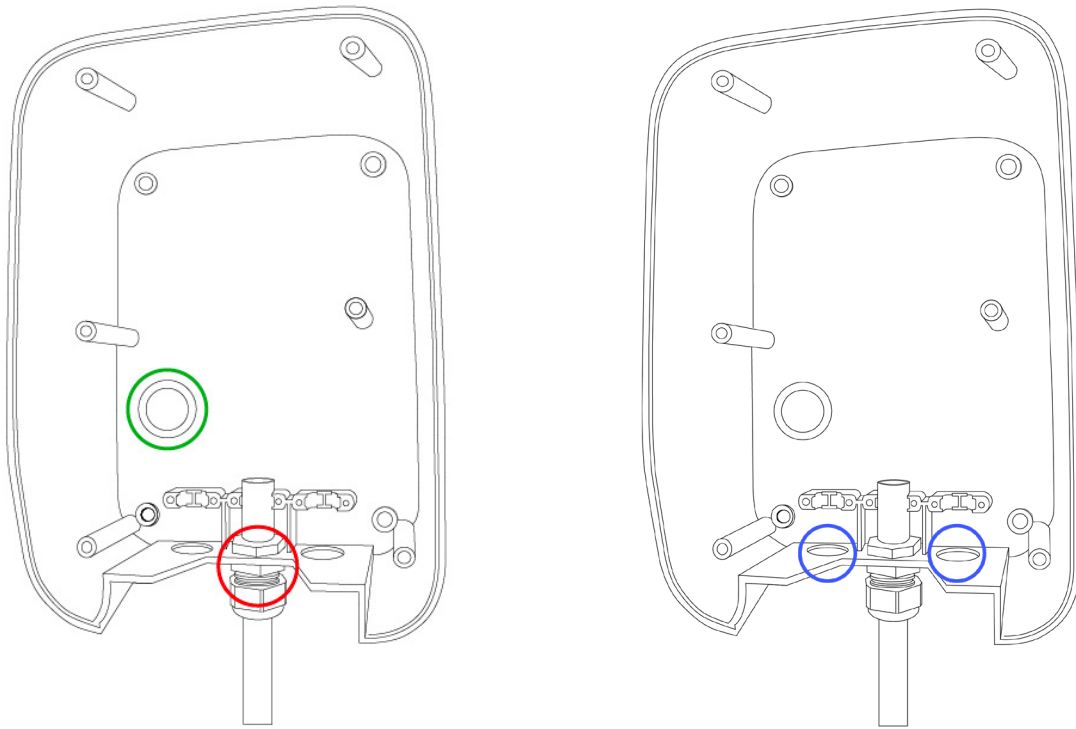

Figure 4: EO Genius 2 rear housing.

The number of glands required will be dependent on the specific installation requirements of each site. When fitting the charger to an EO Post, we recommend you use the rear entry aperture as it accommodates wiring through to the post wiring access port.

4. Offer the base of the EO Genius 2 or the enclosed template up to the installation location. Please make sure the surface is flat and level.

Level the EO Genius 2 base and mark the position of the four holes. Take the EO Genius 2 base away and drill the four holes.



Do not drill through the EO Genius 2 base or base screw holes.

5. Attach the EO Genius 2 base to the wall using four screws. Ensure that the base is the correct way up and that it is flush against the wall. For uneven surfaces we recommend using the optional backplate.

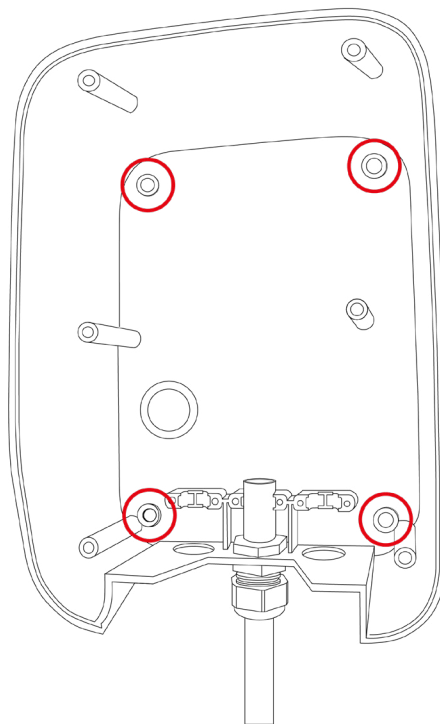

Figure 5: EO Genius 2 rear housing displaying 4 rear entry holes.

6. For installation to an EO Post, make sure all necessary cables have been routed up through the post, and secure the backplate to the post using the fixings supplied within its packaging. Offer up the EO Genius 2 rear case to the backplate and secure the 5mm hex bolts provided in the backplate fixing kit.

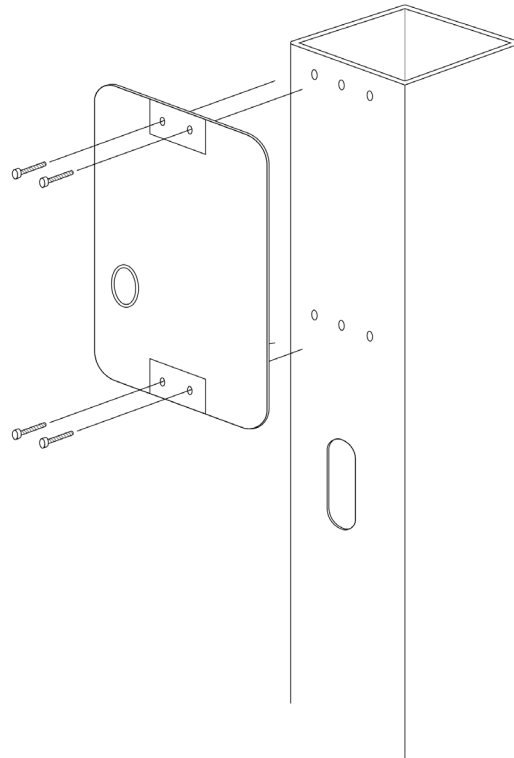

Figure 6: EO Genius 2 backplate post mounting.

- Strip and prepare the power cable and feed it into the desired entry point, depending on your installation type. The figure below shows the cable routed through the rear.

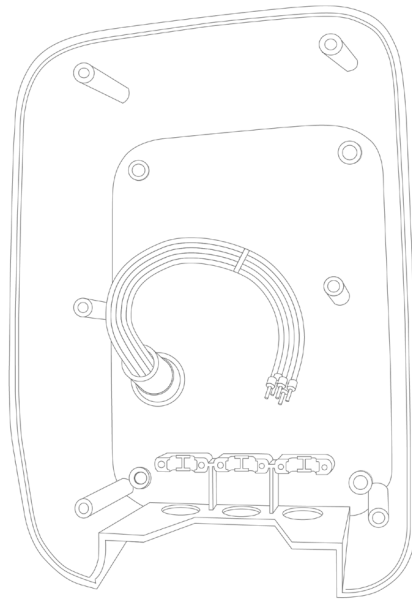

Figure 7: EO Genius 2 with rear cable routing.

- For wall mounting, either of the cable entry positions can be used. We strongly recommend the use of ferrules where multi-strand wires are being used. This will therefore increase the contact area between the connector and wire, reducing any risk of heat generation during operation. Strip back 30 to 40cm of outer sheath allowing for efficient internal routing.

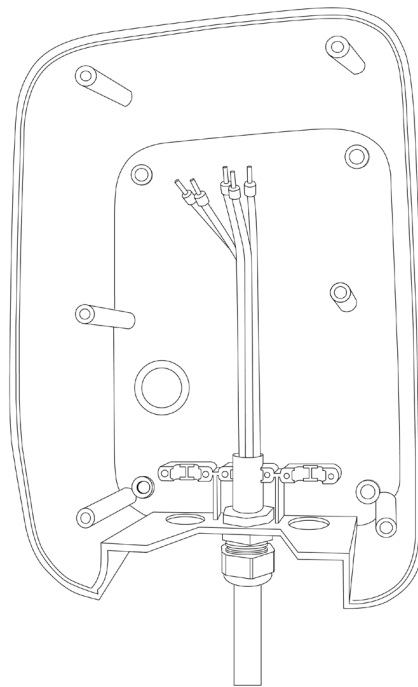

Figure 8: EO Genius 2 with bottom cable routing.

- Feed the other end of the cable into the base EO Genius 2 ready for connection to the charger cartridge.

- Secure both the power and Ethernet LAN cables to the rear housing making sure to fit grommets and compression glands accordingly.

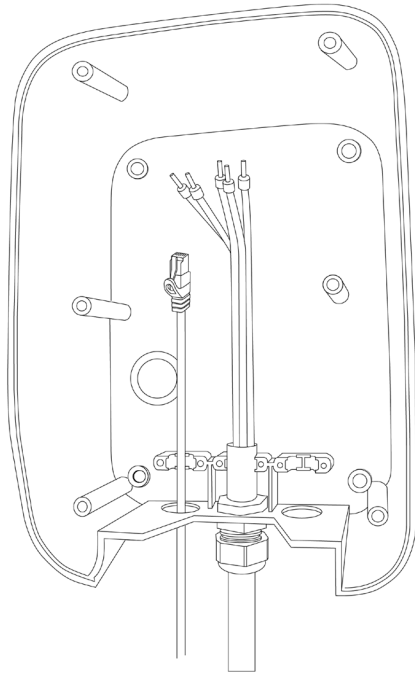

Figure 9: Ethernet and power cables secured to rear housing.

- Connect the power cables to the DIN rail power connector of the EO Genius 2. Insert a small flat-blade screwdriver into the DIN rail terminal to allow the power cable to be inserted. Remove the screwdriver to secure the power cable in place. We strongly recommend the use of ferrules where cable type permits.

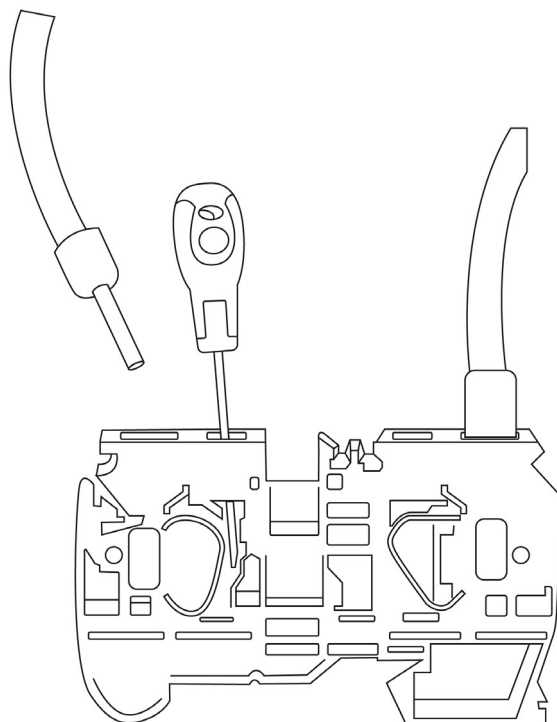
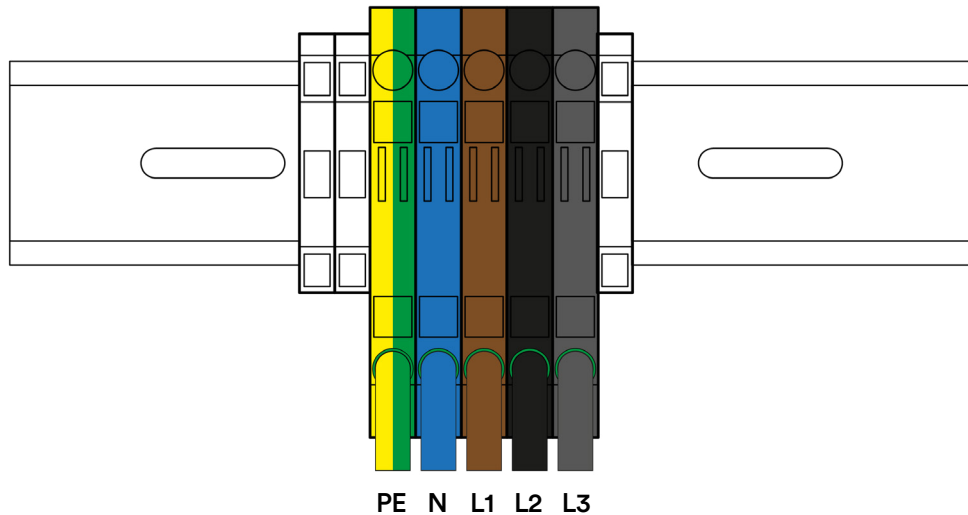

Figure 10: DIN Rail.



PE = Protective Earth
 N = Neutral
 L1 = Line/Phase 1
 L2 = Line/Phase 2
 L3 = Line/Phase 3

Figure 11: DIN Rail colour coding.

12. With all cables connected position them so that you can close the EO Genius 2 front plate to the EO Genius 2 rear housing, making sure that no cables are trapped.

Secure the Genius 2 cartridge to the EO Genius 2 rear chassis. We recommend starting with the two centre bolts followed by the four corner ones.

Note: Do not over tighten these bolts.

Note: Attaching the Fascia to the EO Genius 2 should be carried out after **all testing is complete**.



Figure 12: EO Genius 2.

The image below shows a typical example of a Genius 2 system connected to a LAN. Chargers can be connected via Ethernet to an existing or standalone LAN.

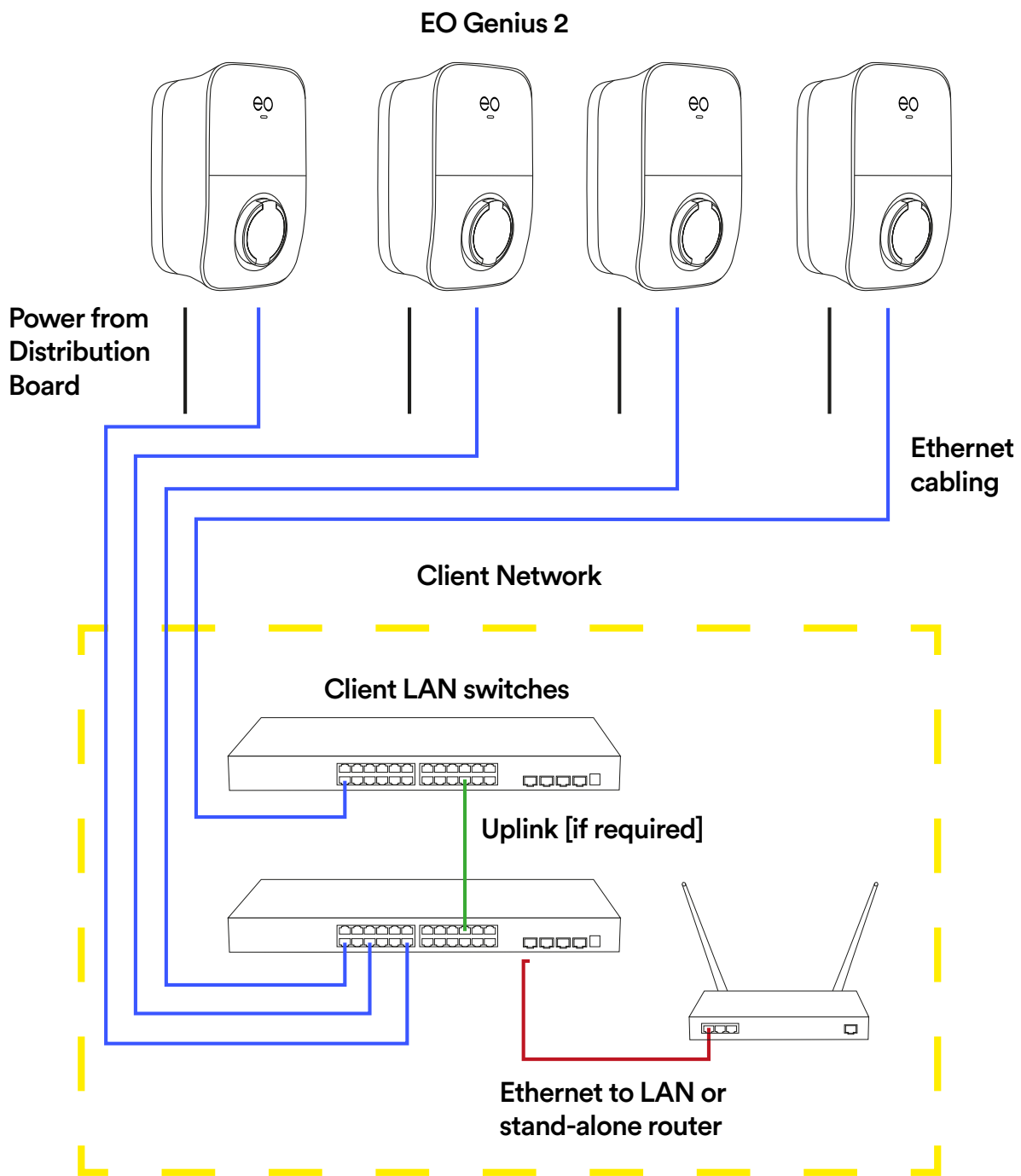

Figure 13: LAN connection diagram example.



2.2 IMPORTANT CHARGER INFORMATION

Topic	Note
Characteristics of power supply input	Permanently connected to 230V
Characteristics of power supply output	Supplies 230V AC to the vehicle
Normal environmental conditions	Can be installed indoors or outdoors
Access requirements	Can be installed with no access restrictions
Mounting method	Stationary equipment intended for surface or post mounting
Protection against electric shock	Class I equipment
Charging mode	Mode 3 charging equipment
Ventilation during the supply of energy	Does not support ventilation during charging
Ingress protection	IP54
Mechanical strength	IK08
Operating temperature	-25°C to +50°C
Height of installation	The charging equipment should be mounted with the bottom face of the enclosure at least 0.9m above ground level. For tethered units, the holster height should be between 0.5 & 1.5m above ground level.
Usage of adaptors/cord extension sets	Adaptors and conversion adaptors sets are not permitted to be used with the equipment. Cord extension sets are not permitted to be used
Maximum altitude	2000m
Pollution degree	Pollution Degree 2
Type of earthing system	TN, IT, TT
Skill level	Operation by ordinary – Installation by skilled authorised electrician



Topic	Note
EMC classification	EN 61851-21-2;2021 Residential & Non-Residential EN 55032:2015 + A1:2020 Class B ENSI EN 301 489-1 V2.2.3:2019 EN 300 328 V2.2.2:2019 EMC Directive 2014/30/EU & UK Electromagnetic compatibility Regulations 2016
Nature of Short-circuit protective device	Upstream RCD Type A required Internal: 6mA DC Leakage, PEN, LoE, LoN
Dimensions and weight	Genius 2 3PH UK (EG203-PME-DCL) 3.628kg Genius-2 1PH UK (EG201-PME-DCL): 3.338kg Genius-2 3PH INT (EG203-DCL): 3.55kg Genius-2 1PH INT (EG201-DCL): 3.25kg Genius-2 3PH UK Tethered (EG203-PME-DCL-T2T): 6.644kg Genius-2 1PH UK Tethered (EG201-PME-DCL-T2T or T1T): 5.348kg Genius-2 3PH INT Tethered (EG203-DCL-T2T): 6.56kg Genius-2 1PH INT Tethered (EG201-DCL-T2T or T1T): 5.25kg Dimensions : 330mm x 220mm x 130mm
Access restrictions	Both restricted and unrestricted
Torque setting for main chassis screws	6Nm
Measures for protection against electric shock	Where the EO Mini Pro 3 includes internal 6mA DC leakage protection (DCL option), then a 30mA Type A RCD must be fitted at the supply. Otherwise, a Type B RCD or equivalent should be used. EO recommends a 40A supply for a 32A charging station. Overcurrent protection (e.g. MCB) should be installed upstream of the charging station.
Short circuit protection of the charging cable	40A Type B or Type C MCB with a maximum I _{2t} of + Socket version should be ≤ 75000 A ² s + Tethered version should be ≤ 80000 A ² s.
Overvoltage category	Category 3
Rated Insulation Voltage	230V (1ph), 440 (3ph)
Rated impulse withstand voltage U _{imp}	4000V
Rated peak withstand current (I _{pk})	≤ 80kA ² s
Rated short time withstand current (I _{cw})	N/A



Topic	Note
Rated conditional short-circuit current of an ASSEMBLY (I _{cc})	5000A2s



Important: *The installer must select the RCD and earthing configuration by following the current local regulations and best practices . The installer must follow national usage guidelines to ensure the unit is installed in accordance to any local restrictions. For the UK refer to the current IET code of practice.*

→ 3.0 WIRING CONNECTIONS

It is possible to configure the EO Genius 2 to connect to either TN or IT grid types which are shown in the following section.

3.1 PHYSICAL CONNECTIONS

Wiring system	Power connections on EO Genius 2				
	PE	N	L1	L2	L3
TN (400V)	PE	N	L1	L2	L3
IT (230V)	PE	L1	L2	L3	

PE = Protective Earth

N = Neutral

L1 = Line/Phase 1

L2 = Line/Phase 2

L3 = Line/Phase 3

3.2

The phase rotation and grid selection (IT/TN) should be set as per the instructions.

The EO Genius 2 is now physically installed and the commissioning of the charger can now begin.

Congratulations, you have successfully completed the hardware installation for the EO Genius 2. There are now two different ways our charger can be configured:



↳ SOFTWARE CONFIGURATION

→ 4.0 SOFTWARE CONFIGURATION OF THE EO GENIUS 2

The following steps should be taken by the installer to prepare the EO Genius 2 so that it can be connected to a 3rd party back-office or the EO Cloud using the OCPP protocol.

The main sequence of steps will be as follows:

1. Power up the Charger.
2. Access the Charger's internal User Interface.
3. Set all parameters relating to wiring and charging requirements.

After all the settings have been applied, the unit will be ready manage on your chosen back-office.

4.1 INITIAL STEPS

1. Ensure that the EO Genius 2 is powered up.
2. Installer Access Label stuck to the charger center section or packaging and place in a safe location as the details are unique to each charge point.

During 'Power Up' the LED will be white whilst the unit is booting up. When the device is ready, the LED will pulse blue. You are now able to connect to the charger and accessing the user interface.

4.2 LOG IN TO THE GENIUS 2 USER INTERFACE.

For the commissioning of the EO Genius 2, the charger has an internal UI.

You will need to access each charger interface, in turn, to carry out configurations.

The charger interface is available via a Wi-Fi hotspot. The Wi-Fi hotspot is only available for 10 minutes after powering up the charger.

1. When powering up the EO Genius 2, a Wi-Fi hotspot is emitted for 10 minutes by default, allowing a connection to be made with a laptop.
2. The hotspot name is represented as the charger serial number, for example, eo-1234567891234. The password for joining this hotspot can be found on the label stuck to the inside of the packaging (see following page). We recommend you take a photo of the label prior to closing the charger.



Figure 14: Example hotspot password Installer label found with the Genius 2.

3. Once connected to the charger Wi-Fi hotspot open your web browser and enter the following IP address 10.10.10.1 in the search bar.

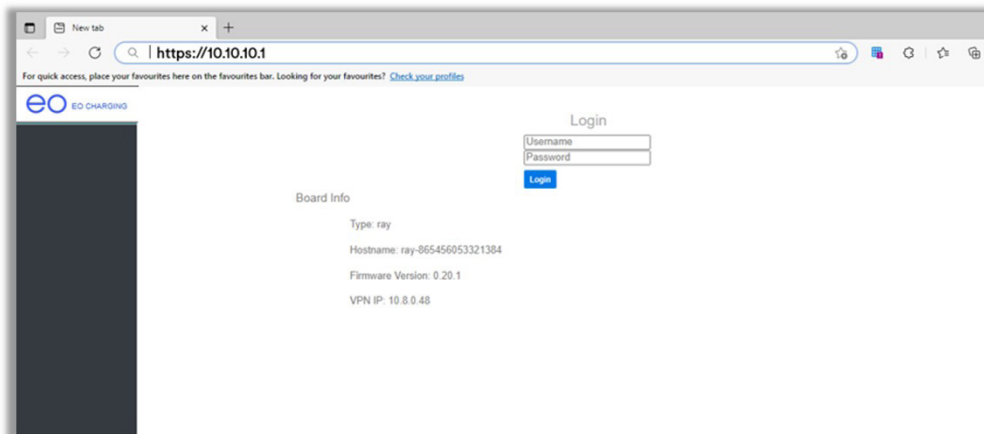

Figure 15: EO Charging UI login page.

You should reach the UI login page where you will need to enter the username which is **“Installer”** and the unique password which can be found on a label stuck to the inside of the charger packaging, see figure 14 for an example of credentials label for reference.

Note: Each charge point will have its unique pass-code. We recommend the Installer Label is retained if not fixed to the charger and other documentation and credentials be handed to your client for safe keeping as may be required at a later date.

4.3 CONFIGURE THE DEVICE PARAMETERS.

Once the installer is logged in then there are several pages that can be configured by the installer:

4.3.1 INFO PAGE

The first page you are presented with is the general Info screen showing such details as:

1. Charger connection status.
2. IP address. [When configured or If on a LAN or GSM]
3. Charger Hostname/Serial number.

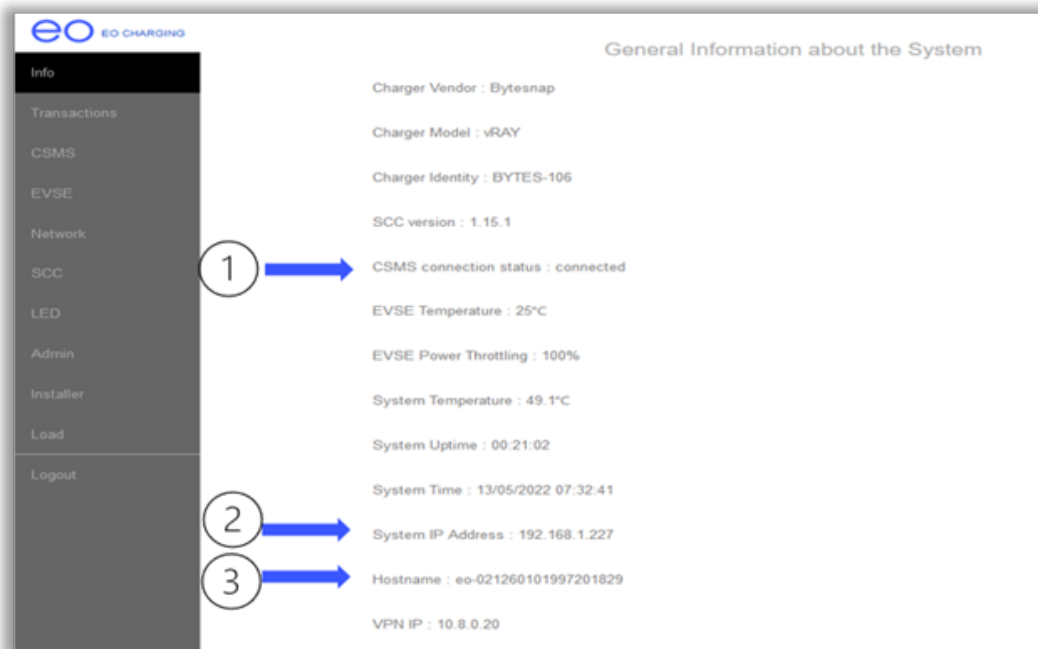

Figure 16: Device information page.

4.3.2 CSMS PAGE

1. The charger's online status will display here once commissioned or connected to a LAN.
2. The connection URL of the OCPP server. A CPO [Charge Point Operator] should amend this URL and point towards their back-Office of choice.
3. If remote authorisation via the back-office is required set the "Authorisation via CSMS server" toggle to on. Doing so will only allow a session to begin once accepted by the platform.
4. RFID can be enabled or disabled.

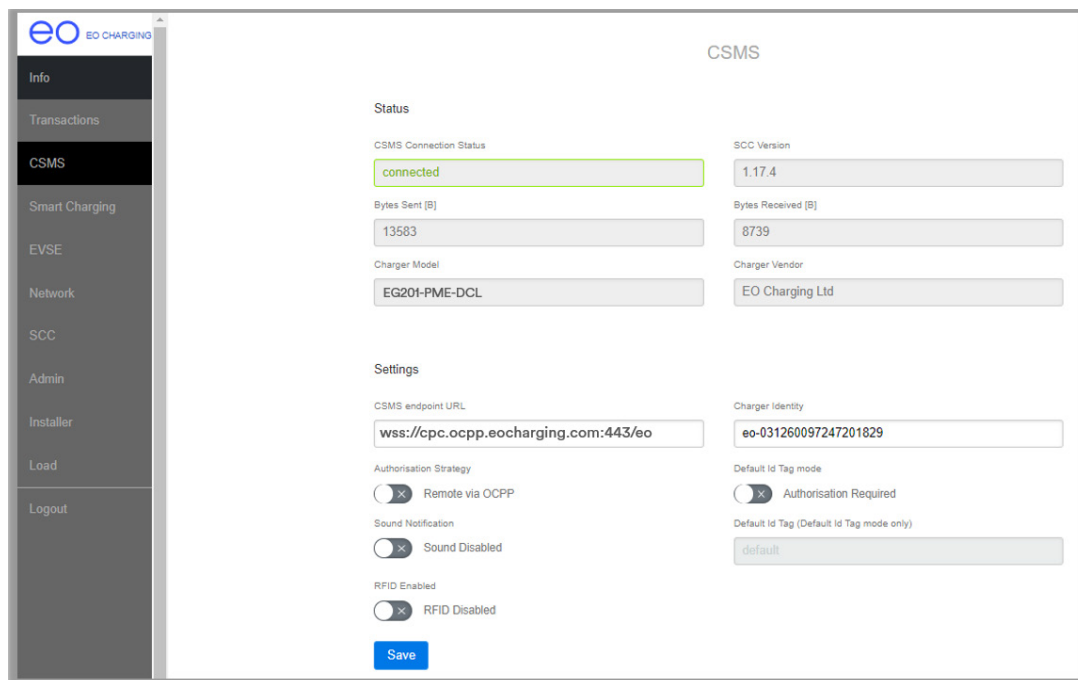

Figure 17: EO charging software CSMS page.

4.3.3 SMART CHARGING PAGE

A charging profile is enabled by default.

This may need to be adjusted to suit clients charging requirements. This setting can only be changed via the charger UI so any future changes to this setting would need to be amended here.

The randomised delay is set to 600s or 10 minutes. This setting forces the charger to offer power to a vehicle anywhere between 0 and a 10 minute interval. The value can be amended if required.

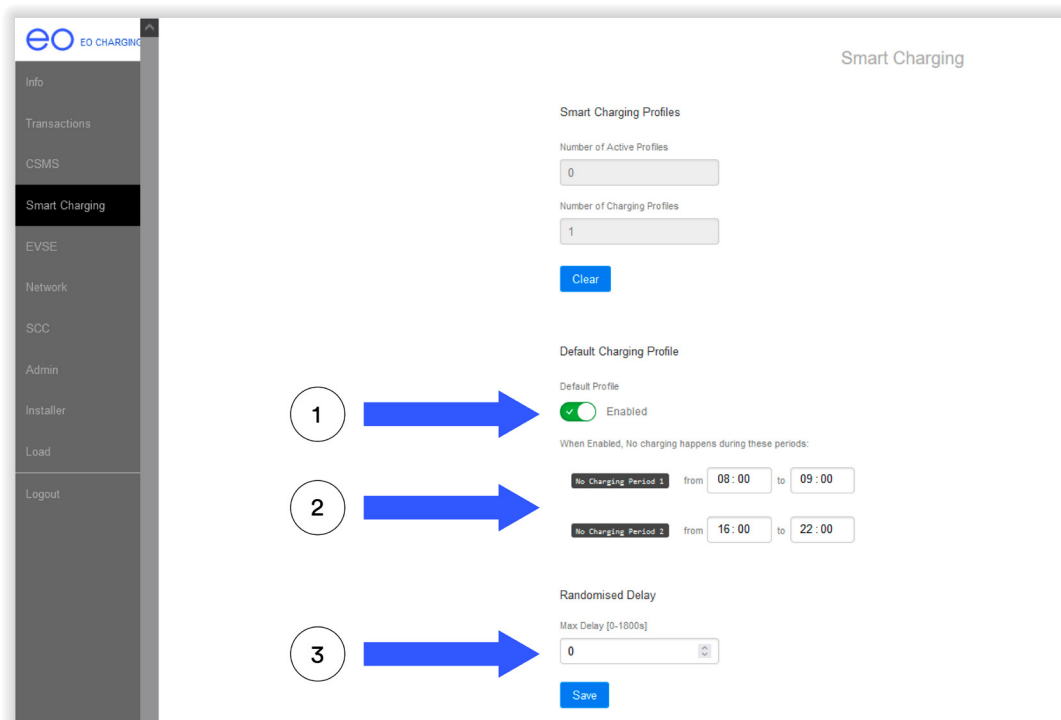

Figure 18: EO charging software smart charging page.

4.3.4 NETWORK LAN / WI-FI PAGE

The Network page provides you with the ability to modify or change charger connection methods. Options are Ethernet, Wi-Fi or GSM.

LAN / ETHERNET.

1. DHCP is on by default. Turn this off if your client has specified a STATIC IP address for the charger. Manually enter the IP and Gateway address if STATIC is being used.
2. At the bottom of the page, you will find a “Modem” section showing SIM status details. Modem settings are not to be changed unless advised by EO Support.

WI-FI

1. If using Wi-Fi, make sure to enable both the WiFi & DHCP buttons to the “on” position.
2. Manually enter the router SSID and password provided by your client and save your settings.

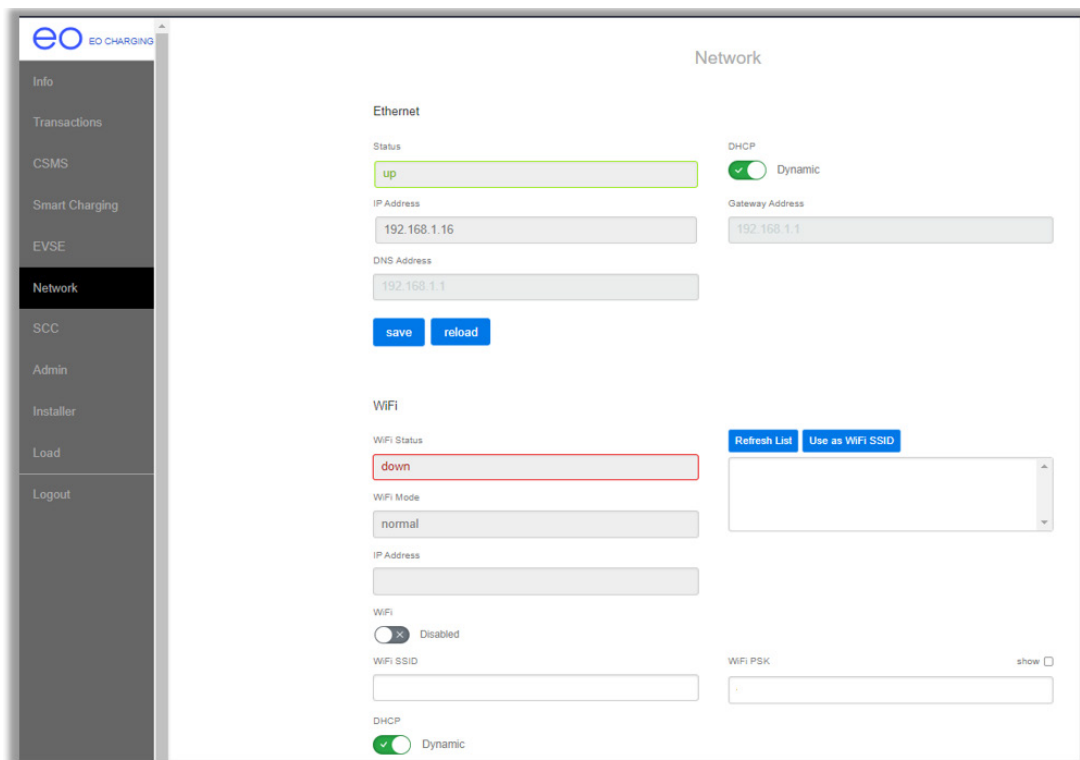

Figure 19: EO charging software smart charging page.

4.3.5 NETWORK GSM - EO SIM PAGE

Guidance for units which are GSM-enabled with an EO SIM.

1. At the bottom of the Network page, you will find a “Modem” section showing SIM status details.

2. Modem status message:

2.1 **SIM Status:** This shows the charger can see the SIM and communicate with it.

2.2 **IP:** Displays the IP address assigned by the network provider.

2.3 **PING Test:** Displays a successful communication ping to the back office.

2.4 **RSSI:** Signal strength.

These settings are not to be changed unless advised by EO Support.

The screenshot displays the 'Modem' configuration page with the following fields and controls:

- ICCID:** 89883040000025337051
- IMSI:** 206018131523705
- IMEI:** 865456053290407
- COPS:** Automatic, O2 - UK, User-specified GSM access technolo
- RSSI [dBm]:** -66 (circled 2.4)
- SIM Status:** SIM OK (circled 2.1)
- IP:** 129.168.2.30 (circled 2.2)
- PING IP:** 8.8.8.8
- PING Test:** 2.5ms (circled 2.3)
- Buttons:** restart modem (interface + service), refresh modem info
- APN:** wlapn.com
- Username:** JUUCELIM
- Password:** [masked]
- show** checkbox
- save** button

Figure 20: Modem information page.

3. Connection via GSM will not occur unless the following conditions are considered.

- A. Ethernet must not be connected.
- B. Wi-Fi should be disconnected or disabled.
- C. Hotspot connection should have timed out.

4.3.6 INSTALLER PAGE

1. Check your time zone and adjust it as required.
2. Set the charger maximum out value in Amps. This value should not exceed 32Amps.
3. Enter your name, company, and email address.
4. Enable the “Tilt/Bump” function, set the degrees in both boxes to “1” and click “Save & Calibrate”.



Figure 21: EO charging software installer page.

5. Select the charger type whether “Single” or “Three Phase” making sure to amend the phase connection according to charger phasing at point of wiring the device.
6. If an external CT’s are fitted, enable the option.
7. Enter the values for each clamp fitted and set the “CT Type” to “Site”.
8. Save your settings and calibrate making sure all clamps are connected at both ends.

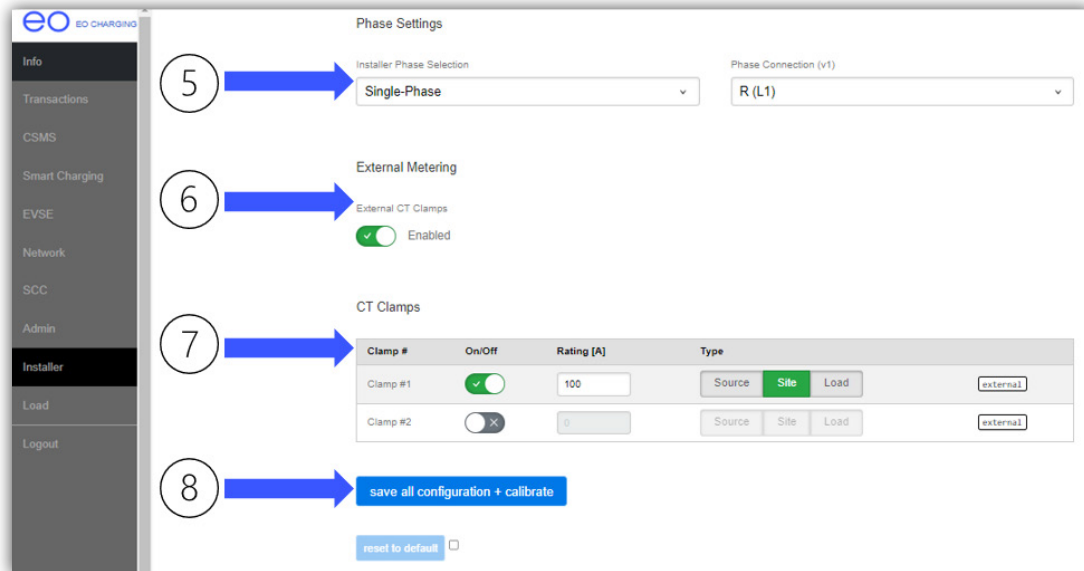

Figure 22: CT rating and type.

CT TYPES EXPLAINED:

Source: An external source that is pushing energy into the site.

Site: Boundary point into a property which will contain the charger usage within it.

Load: An external load to the charger which will not contain the charger usage.

4.3.7 LOAD PAGE

1. Toggle on/off as required.
2. Set the desired safety margin in Amps.
3. Select static or Dynamic balance.
4. Make sure to enter the site value. This will be the site or distribution board load capacity.

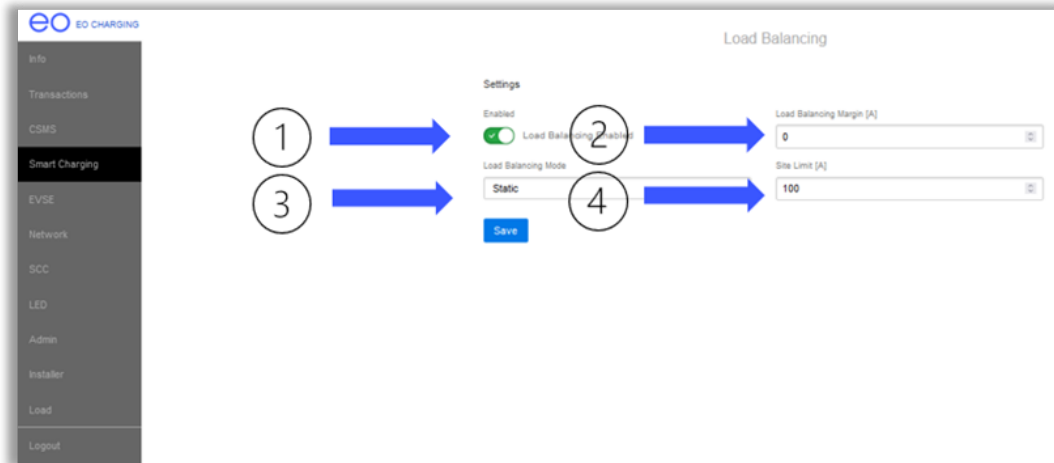

Figure 23: EO charging load balancing page.

→ 5.0 EO GENIUS 2 POWER UP

The EO Genius 2 has a status LED on its front face providing the user with its current status. Below describe the interpreted LED flash codes.

5.1 CHARGER STATUS LIGHT ON POWER-UP

The following LED sequence should be observed:

LED colour	State	Notes
Not illuminated	Power off	No power is available EVSE
LED solid white	Initialising	Initialising
LED pulses blue	Ready	The unit has started up successfully and is ready to charge

5.2 NORMAL OPERATION

LED colour	State	Notes
LED pulses blue	Ready	Ready to charge
LED pulses green	Cable is inserted	EO Genius 2 is communicating with the vehicle and trying to start a charging session
LED solid green	Charging	A charging session has started successfully
LED pulses blue	Cable is removed	Ready to charge
LED solid yellow	Paused	The EO Genius 2 has been put on pause by the third-party OCPP server
LED pulses red	Fault condition	A fault has occurred and the communication logs and, if necessary, the diagnostic logs should be consulted

→ 6.0 ADDITIONAL INFORMATION

6.1 FIRMWARE UPDATES

Periodically new firmware images will be released by EO to the CPO customers. EO mandates that these new firmware images must be uploaded to the Genius 2 charging stations as soon as possible as they may contain security improvements.

6.1.1 RECEIVING THE FIRMWARE IMAGES

1. Contact cposupport@eocharging.com and ask to be put onto the firmware image release mailing list.
2. Periodically cposupport@eocharging.com will send out new firmware images with release notes.

6.1.2 APPLY THE IMAGES

The firmware images can either be applied via the back-office using the standard OCPP firmware update commands or they can be applied to the device directly:

1. Log onto the charging station
2. Go to the Admin page
3. Upload the zip file

System Update



The screenshot shows a web interface for system updates. It features a text input field with the placeholder text "Choose Update zip file", a "Browse" button to the right of the field, and a blue "install update" button to the right of the "Browse" button.

Figure 24: EO Charging Software Systems updates.

6.2 SECURITY

By default, over 100 common root certificates have been preloaded onto the Genius 2. However, if a custom root certificate needs to be added to the charging station then the following sequence should be followed:

1. Connect to the CSMS using the ws connection.
2. Use the OCPP Install Certificate command to download the new certificate.
3. Change to the wss connection and the EO Genius 2 should now be able to connect to the CPOs CSMS.

6.3 TROUBLE SHOOTING

In the case of problems, EO Support may request the diagnostic logs from the charging station. These logs can be accessed from the Admin page.

1. Load the Admin page.
2. Click on the “download” button in the SCC logs.
3. A compressed file will be downloaded.
4. Email the downloaded log file to EO Support.

System Logs

SCC Logs

download

Figure 25: EO Charging Software Systems logs.

6.4 PEN FAULT DETECTION

If the Genius 2 is fitted with the PEN Fault Detection system (model designator -PME), then the Genius 2 will detect errors in the incoming grid connection. If a PEN fault is detected then the vehicle will be fully isolated from the charging station and the LED shall illuminate solid RED. It shall not be possible to charge a vehicle in this condition. In order to restart charging:

- + The vehicle must be unplugged from the charging station.
- + The Genius 2 must be power cycled or remotely reset.
- + If the LED remains RED then the grid connection is still not within the defined safety limits and an installer must be contacted to inspect the incoming supply. If the normal pulsing Blue LED is shown then the system is safe to use.

6.5 FINAL NOTES



All charging stations installed should be completely tested and signed off as functioning using dedicated EV test equipment.

An electrical and charger test certificate should be left with the client once all work is complete where appropriate.

→ 7.0 EO SUPPORT CENTRE

All EO Charging technical documentation is published in the EO Resource Centre, this is found at: <https://www.eocharging.com/support>.

The EO Support team can be reached at:

Email: support@eocharging.com

Phone: +44 (0) 333 77 20383



This document contains information that is subject to change without notice.

The latest version of this publication can be downloaded at:

<https://www.eocharging.com/support/commercial-solutions/eo-genius-2>



Disclaimer: *No part of this publication may be reproduced or transmitted in any form or by any means, electronic or mechanical, including, but not limited to, copying, recording, retrieving data, or computer networks without the written permission of EO Charging.*

